

STORAGE & HANDLING OF ANHYDROUS AMMONIA

TANNER INDUSTRIES, INC.

DIVISIONS
NATIONAL AMMONIA
BOWER AMMONIA & CHEMICAL
NORTHEASTERN AMMONIA
HAMLER INDUSTRIES

735 DAVISVILLE ROAD, THIRD FLOOR
SOUTHAMPTON, PA 18966

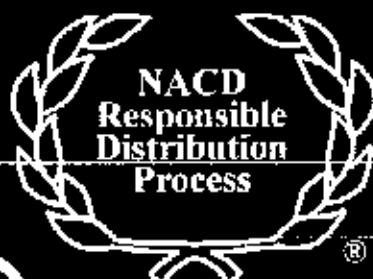

Documentation Verification
Assessment 1995
File T7 NC2068

CUSTOMER MANUAL - ANHYDROUS AMMONIA

INTRODUCTION	2
ANHYDROUS AMMONIA PROPERTIES	3
PHYSICAL CONSTANTS OF ANHYDROUS AMMONIA.....	3
PROPERTIES OF LIQUID ANHYDROUS AMMONIA AT VARIOUS TEMPERATURES	4
REACTIVITY OF ANHYDROUS AMMONIA	4
DISSOCIATED ANHYDROUS AMMONIA	5
ANHYDROUS AMMONIA QUALITY	5
SIZING ANHYDROUS AMMONIA STORAGE TANKS	6
ANHYDROUS AMMONIA STORAGE TANK LOCATION AND DESIGN	7
ANHYDROUS AMMONIA VAPOR WITHDRAWAL	8
ANHYDROUS AMMONIA VAPORIZERS	9
VAPORIZER ELECTRICAL CONNECTIONS	9
ANHYDROUS AMMONIA LIQUID WITHDRAWAL	10
PIPING SYSTEMS FOR ANHYDROUS AMMONIA.....	10
ANHYDROUS AMMONIA SYSTEM MAINTENANCE	11
AMMONIA LEAKS	12
SAFETY	14
VAPORIZER WIRING DIAGRAM	15
TYPICAL STORAGE TANK WITH VAPORIZER	16
TANK INSTALLATION DRAWING	17
VAPOR PRESSURE-TEMPERATURE CURVE	18

INTRODUCTION

The purpose of this brochure is to provide our customers with sufficient information to assure continuous and safe use of their ammonia storage system.

Anhydrous ammonia is classified by the U. S. Department of Transportation and Occupational Safety and Health Administration (OSHA) as a hazardous material and by the Environmental Protection Agency (EPA) as an extremely hazardous substance (EHS), however, by using proper procedures and care in handling, the possibility of a hazardous situation occurring can be virtually eliminated.

First read the literature contained herein and familiarize yourself with the properties of ammonia and the general information pertaining to its safe handling.

Next, study Drawing 8011 which shows typical tank appurtenances. Examine your tank and system and identify each component. Become familiar with its location, operation and purpose.

This brochure should be studied and retained for reference. Do not wait for a malfunction or emergency condition to occur before learning how the system operates. A knowledge of the system operation and a knowledge of the purpose of each component will enable you to look for potential problems before they occur, determine what action is necessary and to be prepared for an unexpected or emergency situation.

If you have any questions or require assistance, please contact us at our toll free number, 1-800-643-6226.

ANHYDROUS AMMONIA PROPERTIES

Anhydrous ammonia is the compound formed by the combination of the two gaseous elements, nitrogen and hydrogen, in the proportion of one part of nitrogen to three parts of hydrogen by volume. Since one volume of nitrogen weighs fourteen times as much as one volume of hydrogen, on a weight basis, the ratio is fourteen parts of nitrogen to three parts of hydrogen, or about 82% nitrogen and 18% hydrogen.

At atmospheric temperatures and pressures, anhydrous ammonia is a pungent colorless gas. Anhydrous ammonia boils at -28°F and freezes to a white crystalline mass at -108°F . When heated above its critical temperature of 270.3°F ammonia exists only as a vapor regardless of the pressure. Between the melting and critical points, liquid ammonia exerts a vapor pressure which increases with rising temperature. When liquid ammonia is in a closed container it is in equilibrium with ammonia vapor and the pressure within the container bears a definite relationship to the temperature. See the Table on the following page and DWG. 8019.

Liquid anhydrous ammonia is lighter than water, having a density of 42.57 pounds per cubic foot at -28°F , while as a vapor, ammonia is lighter than air, its relative density is 0.597 compared to air at atmospheric pressure and a temperature of 32°F . Under the latter conditions, one pound of ammonia vapor occupies a volume of 20.78 cubic feet. At 70°F and at atmospheric pressure, one pound of ammonia vapor occupies a volume of 22.5 cubic feet and yields 45 cubic feet of dissociated gas at a ratio of 25% nitrogen and 75% hydrogen.

Because of its great affinity for water, care must be taken in the storage and handling of ammonia to keep it dry. "Anhydrous" means "without water". When ammonia gas is dissolved in water, the resulting material is ammonium hydroxide or "aqua" ammonia. The two materials should not be confused.

PHYSICAL CONSTANTS OF ANHYDROUS AMMONIA

Molecular symbol	NH ₃
Molecular weight	17.032
Boiling point at one atmosphere	-28°F
Freezing point at one atmosphere	-108°F
Critical temperature	270.32°F
Critical pressure	1657 psia
Vapor density at -28°F and one atmosphere	0.056697 lb./cu. ft.
Heat of Combustion	8001 BTU/lb

PROPERTIES OF LIQUID ANHYDROUS AMMONIA AT VARIOUS TEMPERATURES

Temp. °F	Vapor press. Psig.	Liquid Density		Spec. Gr. Liq. Comp. Water 4°C	Latent Heat Btu per lb.
		Lbs./cu. ft.	lbs./U.S. gal.		
-28°	0.0	42.57	5.69	.682	589.3
-20°	3.6	42.22	5.64	.675	583.6
-10°	9.0	41.78	5.59	.669	576.4
0°	15.7	41.34	5.53	.663	568.9
10°	23.8	40.89	5.47	.656	561.1
20°	33.5	40.43	5.41	.648	553.1
30°	45.0	39.96	5.34	.641	544.8
40°	58.6	39.49	5.28	.633	536.2
50°	74.5	39.00	5.21	.625	527.3
60°	92.9	38.50	5.14	.617	518.1
65°	103.1	38.25	5.11	.613	513.4
70°	114.1	38.00	5.08	.609	508.6
75°	125.8	37.74	5.04	.605	503.7
80°	138.3	37.48	5.01	.600	498.7
85°	151.7	37.21	4.97	.596	493.6
90°	165.9	36.95	4.94	.592	488.5
95°	181.1	36.67	4.90	.588	483.2
100°	197.2	36.40	4.87	.583	477.8
105°	214.2	36.12	4.83	.579	472.3
110°	232.3	35.84	4.79	.573	466.7
115°	251.5	35.55	4.75	.570	460.9
120°	271.7	35.26	4.71	.565	455.0
125°	293.1	34.96	4.67	.560	448.9
130°	315.6	34.66	4.63	.555	443.0
135°	339.4	34.35	4.59	.550	436.0
140°	364.4	34.04	4.55	.545	429.0

REACTIVITY OF ANHYDROUS AMMONIA

The common metals are not affected by dry ammonia. Moist ammonia will not corrode iron or steel, but will react rapidly with copper, brass, zinc and many alloys, especially those containing copper. Only steel or ductile iron should be used for ammonia containers, valves, fittings and piping.

Under normal conditions, ammonia is a very stable compound. It takes excessive temperatures (about 840° to 930° F.) to cause it to dissociate slightly at atmospheric pressure. When this happens, the dissociated products are nitrogen and hydrogen. Ammonia gas burns in a mixture with air within a limited range. The flammable limits at atmospheric pressure are 15% to 28% by volume of ammonia in air. Experiments conducted by the Underwriters Laboratories indicate that an ammonia-air mixture in a standard quartz bomb will not ignite at temperatures below 1562° F. When an iron bomb, having a catalytic effect, was used, the ignition temperature dropped to 1204° F.

The following sources of information on anhydrous ammonia are recommended.

Pamphlet G-2, Anhydrous Ammonia
Compressed Gas Association
Phone 703-412-0900
1725 Jefferson Davis Highway
Arlington, VA 22202

Storage and Handling of Anhydrous Ammonia
29 CFR 1910.111
Code of Federal Regulations, Title 29-Labor

Pamphlet ANSI K61.1
Safety Requirements for the Storage & Handling of Anhydrous Ammonia
American National Standard Institute
1430 Broadway
New York, NY 10018

Ammonia Data Book
International Institute of Ammonia Refrigeration
Phone 202-857-1110
101 Connecticut Ave. NW, Suite 700
Washington, DC 20036

DISSOCIATED ANHYDROUS AMMONIA

Dissociated ammonia is frequently used as a furnace atmosphere for heat treating metals. Dryness is an important factor. It is difficult to measure the moisture content of the ammonia; however, the moisture content of the dissociated gas can be readily determined by measuring its dewpoint.

ANHYDROUS AMMONIA QUALITY

The standards of quality for anhydrous ammonia differ depending on the manufacturer. All standards or specifications call for some minimum assay or content of ammonia, some maximum content of moisture and some maximum content of oil. Assay measurements are given in percent while moisture and oil content are generally given in parts per million (1ppm = 0.0001%). The difference between 100% and the total content of ammonia, moisture and oil is attributed to non-condensable gases.

Anhydrous ammonia, by its very nature, invites contamination by moisture. It is a fact that moisture from the air will travel into an ammonia system through a leak even while the ammonia is coming out. In critical applications, it is of utmost importance that all leaks be promptly corrected. Contamination by oil occurs in the transfer operations where lubricating oil from the compressors and pumps finds its way into the material. The oil settles to the bottom of the container and if the ammonia is being used in the vapor form, very little is carried over into the process. Concentrations of oil building up in a storage tank with high usage should be bled off periodically.

Where quality control testing is deemed necessary, an analysis can be made using an evaporation method as prescribed in Federal Specification O-A-445B. Analyzing anhydrous ammonia by this method is difficult and hazardous and the procedure should not be attempted by unskilled personnel.

Where ammonia is used in its dissociated form, as nitrogen and hydrogen, the moisture content may be measured by means of a dewpoint instrument. For critical applications, it is recommended that a dryer be installed.

Please contact us at 1-800-643-6226 if further information is desired.

SIZING ANHYDROUS AMMONIA STORAGE TANKS

Anhydrous Ammonia liquid weighs approximately 5 pounds per gallon.

A pound of liquid Anhydrous Ammonia will generate 22.5 SCF of ammonia vapor and 45 SCF of dissociated ammonia gas.

A storage tank is usually considered to have an 85% usable capacity. (A 15% vapor space must always be maintained when filling, to allow for expansion).

Consult with our Sales Department for further assistance with sizing a storage tank and frequency of deliveries. Storage tanks are available in a variety of sizes depending on individual requirements.

ANHYDROUS AMMONIA STORAGE TANK LOCATION AND DESIGN

Stationary storage tanks for anhydrous ammonia are regulated by the U.S. Dept. of Labor and must conform to the requirements of 29CFR1910.111. They are built in accordance with the ASME Boiler and Pressure Vessel Code and are rated for 250 psig.

Tanks should be located in an area, preferably outdoors, where they will not be exposed to damage by vehicular traffic, however, access to within 50 feet is generally necessary for tank truck delivery. The area should be clear of debris, weeds or any combustible materials.

If the tank is located where summer sun conditions are severe, provisions should be made for sun shielding. In some area, local codes require diking. Check your local codes.

Tanks should be mounted on concrete, masonry or structural steel supports and on firm concrete or masonry foundations. All foundations should extend below the frost line.

Refer to ANSI K 61.1 for additional information.

In the event of an emergency, access to the tank must be provided. If the tank is fenced in, two to four feet clearance is recommended as a working area for maintenance purposes. Fenced in tanks should also have two means of egress for emergency escape.

All pipe and hose connections to the tank are protected by excess flow valves to prevent massive leakage in the event of a catastrophic line break. Relatively high flows are required to cause these valves to close so it should be noted that a downstream break may not always result in sufficient flow to close the valve.

Pressure gauge connections and the 85% outage gauge are not protected by excess flow valves but they do have a .054" restriction to limit flow. Tank pressure gauges are also equipped with isolating valves which can be closed off in the event of a gauge failure.

The tank is equipped with a dual safety relief valve system consisting of two safety relief valves mounted on a three-way valve. The design of the three-way valve permits shutting off one or the other, but not both, of the relief valves and allows replacement of either of the relief valves without emptying the tank. Either relief valve alone is sized to adequately protect the tank.

Different designs of three-way valves have been used. The "Shank" design has a handwheel. Facing the handwheel, to shut off the right hand safety, turn the hand wheel counter clockwise. To shut off the left hand safety, turn the wheel clockwise. The handwheel should be left in full counter-clockwise position so that the valve stem packing and the right hand safety relief are isolated from the tank pressure.

The "Frick" or "Henry" design valves are of the "in-line" type and may have a conical cap covering the valve stem. If the valve is of this type, the valve stem has flats on it and a wrench must be used. Use caution when removing the cap as it may be under a slight pressure. Turning the valve stem clockwise will shut off the safety relief furthest from the valve stem. Turning the stem counter clockwise will shut off the safety relief nearest the valve stem. The valve should normally be left in the full counter clockwise position so that the valve stem packing is isolated from the tank pressure.

Tank content is determined by means of a float gauge which reads in percent of the total tank capacity. The gauge dial is usually on the top of the tank; however, it may be located at one end. When mounted on a 1,000 gallon tank and reading 60%, the tank would contain 600 gallons. At 5 lbs. per gallon, this would be equivalent to 3,000 lbs.

Do not confuse this gauge with the pressure gauge. The pressure gauge would read the same whether there is 200 gallons in the tank or 800 gallons.

ANHYDROUS AMMONIA VAPOR WITHDRAWAL

Ammonia is shipped and stored in its liquid form, but it is usually utilized in the form of a gas. You will note, under "Properties of Liquid Ammonia at Various Temperatures" that a certain amount of heat, called "Latent Heat of Vaporization" is necessary to convert each pound of liquid ammonia into a gas. If sufficient heat (approximately 500 BTU's per pound) is not available from the ambient air surrounding the tank to provide the latent heat of vaporization required for a certain gas withdrawal rate, this heat will be taken from the liquid remaining in the tank and the liquid temperature will drop. When the temperature drops, the vapor pressure also drops and a point can be reached where there is insufficient pressure available to operate the system.

The situation is further compounded when the outside temperature of the tank reaches freezing and the moisture in the surrounding air freezes on the tank surface. This ice acts as an insulator, further preventing heat from entering the tank.

To counteract this condition, in situations where withdrawal rates are so high that the ambient heat available is not sufficient to sustain the flow, a vaporizer must be used.

As a general rule, for a 1,000 gallon tank, a vaporizer should be considered when vapor withdrawal rates exceed 500 SCFH.

It is strongly recommended that conduit seal fittings and barrier seal compound be used in the electrical conduit with a breather fitting to permit release of vapors to the atmosphere. Although remote, there is always the possibility that a leak in the pressure switch or heating element could cause vapors to be transmitted back through the electrical conduit to the electrical contractor or back into the building. Crouse-Hinds EYS series fittings are recommended.

ANHYDROUS AMMONIA LIQUID WITHDRAWAL

If the ammonia is to be used in liquid form, the ammonia tank fittings are arranged so that the customer's connection is at the bottom of the tank. Tanks can be fitted for a top connection by providing a dip tube inside the tank which runs down to the tank bottom.

Care should be exercised in designing liquid systems to be sure that a hydrostatic relief valve, rated at 350 psig, is used wherever there is the possibility that liquid ammonia could be trapped within a closed system. Without such protection, liquid ammonia's large coefficient of expansion with temperature could produce high pressures causing piping to rupture.

PIPING SYSTEMS FOR ANHYDROUS AMMONIA

Piping for anhydrous ammonia systems should be extra heavy (Schedule 80) steel when threaded joints are used. Standard weight (Schedule 40) steel may be used when joints are either welded or joined by welding type flanges.

La-Co Slic-Tite Pipe Thread Sealer along with Teflon tape has been used successfully as a pipe thread lubricant and sealer and is highly recommended.

All piping should be well supported and provisions should be made to protect the piping against the effects of expansion, contraction, jarring, vibration, settling and external corrosion.

All fittings should be forged steel; non-malleable metals must not be used. Unions should be of the ground joint type. Some unions have brass seats which can not be used.

All piping should be tested for leaks after assembly by introducing ammonia vapor. Do not introduce liquid ammonia initially because, if it is necessary to disassemble the piping to fix the leak, excessive bleed down time will be necessary. Refer to the section covering ammonia leaks.

Wherever there is the possibility of liquid ammonia being locked up between two valves, a hydrostatic relief valve must be used.

Rubber hoses should never be used in permanent installations.

Use only all steel gauges made for ammonia service. Ranges 0-400 and 0-160 psi are available from Tanner Industries, Inc..

ANHYDROUS AMMONIA SYSTEM MAINTENANCE

The responsibility for the maintenance of the ammonia storage tank, piping and appurtenances lies with the user. Little maintenance is required on a well installed ammonia storage system. The tank and piping should be visually inspected at least every three months. Use the "Inspection Check List" included in this manual. All piping, pipe joints, tanks and tank fittings should be examined for signs of corrosion, damage, wear and leaks.

Areas of corrosion should be cleaned, primed and painted. The tank should be painted with either a good grade of white gloss enamel or aluminum paint. The liquid fill valve should be painted orange and the vapor return valve should be painted yellow. Do not paint the small stainless steel vent valves. All markings, warnings etc. should be legible and should be replaced as needed. Contact us for your replacement needs. Do not paint the valve stems as it can get into the stem packing and cause leaks.

Valve stems should be protected and occasionally lubricated with a light coating of grease.

Safety relief valves are provided with caps to keep out rain, snow, dirt, etc. Make sure these caps are in place. Request replacements if needed.

Hose connections must have protective caps. They provide a "secondary" closure and will sustain tank pressure as well as keeping out rain, snow etc. Make sure they are in place and request replacements as needed.

When bleeding down ammonia systems prior to making repairs or alterations, advantage may be taken of ammonia's great affinity for water. Vapors from the bleed point can be transferred by means of a hose to a container of water where they will be absorbed. When ammonia is dissolved in water to form ammonium hydroxide solution, there is liberation of heat from the exothermic reaction which takes place. The solubility of ammonia in water is strongly affected by the solution temperature resulting in decreased solubility at higher temperatures, therefore, the water should be replenished as necessary.

A well maintained system will insure a continuous, economical and safe source of ammonia. Our drivers are trained to supplement your inspection procedures on each delivery. Upon request, they, or our technical personnel, will lend assistance in any inspection or maintenance problems you encounter.

Tank Inspection Check List (Form# TICL-1)

Customer: _____ # _____ Date: _____
 City: _____ State: _____
 Tank Size: _____ Serial No.: _____ Nat'l. Board No.: _____

Circle Problem Area or Areas on Drawing Below:

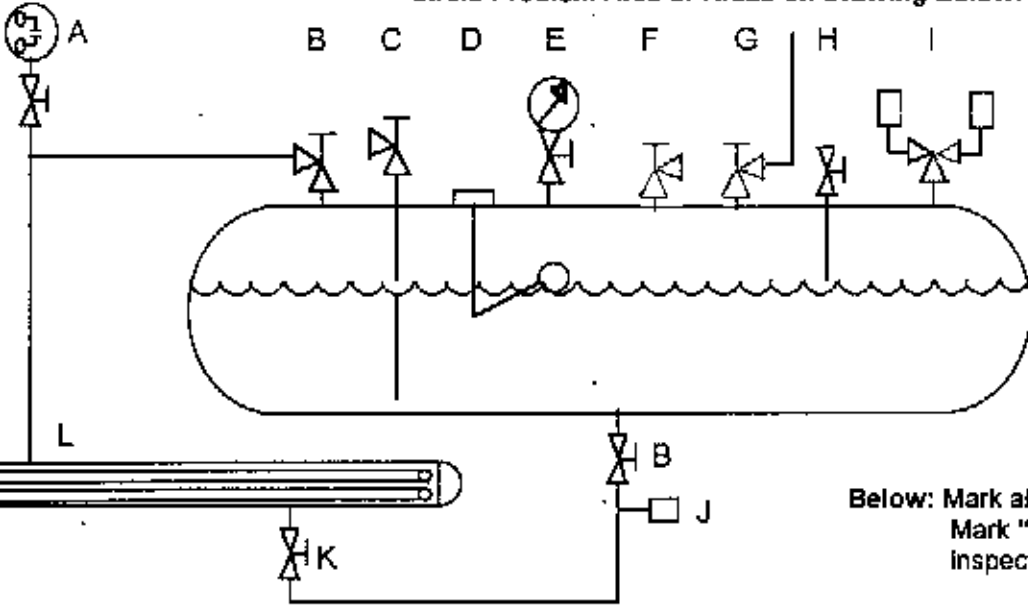

Tank OK

Diagram Notes _____

Below: Mark all problems with an "X" and explain. Mark "Replc" if part replaced at time of inspection.

	Problem	Replaced		Problem	Replaced
A. Pressure Switch Type _____ * Isolating Valve Part# _____	<input type="checkbox"/>	<input type="checkbox"/>	H. 85 % Valve * If none, is opening available opening? _____ Size of opening _____	<input type="checkbox"/>	<input type="checkbox"/>
B. Vaporizer Isolating Valve * Top/Bottom _____ Part# _____	<input type="checkbox"/>	<input type="checkbox"/>	I. Pressure Relief Valves Exp. Date: _____ Part# _____ * Three Way Valve Part# _____	<input type="checkbox"/>	<input type="checkbox"/>
C. Liquid Fill Valve * Part# _____	<input type="checkbox"/>	<input type="checkbox"/>	J. Hydrostatic Relief Valve Part# _____	<input type="checkbox"/>	<input type="checkbox"/>
D. Float Gauge * Top or Side Mount _____ Diam. of Tank _____ Float Gauge Dial Only _____ Type _____	<input type="checkbox"/>	<input type="checkbox"/>	K. Vaporizer Drain Valve Part# _____	<input type="checkbox"/>	<input type="checkbox"/>
E. Pressure Gauge PSI Range _____ * Isolating Valve Part# _____	<input type="checkbox"/>	<input type="checkbox"/>	L. Vaporizer Heat Element KW/Volt/Phase _____ Type _____	<input type="checkbox"/>	<input type="checkbox"/>
F. Vapor Fill Valve * Part# _____	<input type="checkbox"/>	<input type="checkbox"/>	M. "Anhydrous Ammonia" Decals Part# _____	<input type="checkbox"/>	<input type="checkbox"/>
G. Customer Supply Valve * Part# _____	<input type="checkbox"/>	<input type="checkbox"/>	N. "Hazard Warning" Decals Part# _____	<input type="checkbox"/>	<input type="checkbox"/>
			O. ACME Valve Caps Part# _____	<input type="checkbox"/>	<input type="checkbox"/>
			P. Relief Valve Caps Part# _____	<input type="checkbox"/>	<input type="checkbox"/>

(Explain all findings on back of this form if necessary)

* Perform Evaporation Test if Pump Out Required For Valve Replacement.

Is Tank Data Plate intact? Is it Legible? Condition of Paint? _____
 Any Excessive Corrosion, Pitting, Dents, Etc.? _____
 Condition of Vaporizer (Shell & Piping) _____

Inspected By: _____ (Rev: 4/85 Approve: Tech. Serv.)
 Service Agree: _____ Computer Update _____ S/O Entered _____

SAFETY

It is important that personnel understand the properties of ammonia and that they be thoroughly trained in safe practices for its storage and handling.

Please refer to the MATERIAL SAFETY DATA SHEET for some basic safety information. If you do not have a copy, contact Tanner Industries, Inc.

The Code of Federal Regulations (29CFR1910.111) requires that all stationary storage installations have at least two suitable gas masks in a readily accessible location. Suitable gas masks are available from Tanner Industries, Inc. Gas masks must be approved by NIOSH/MSHA for use with anhydrous ammonia. Properly trained personnel can use the full face gas mask in ammonia concentrations less than the IDLH. Concentrations above the IDLH would require the use of a NIOSH approved positive-pressure, self-contained breathing apparatus (SCBA).

The Code further requires that all stationary storage installations have an easily accessible emergency shower and an eyewash unit or a 50 gallon open container with clean water.

29CFR1910.132, .133 and .134 should be consulted regarding eye and face protection and respiratory protection where employees are working directly with anhydrous ammonia.

NOTICE

The information contained in this brochure was obtained from sources believed to be reliable, and is based on technical information excerpted, in part from Pamphlet G-2 published by the Compressed Gas Association and Pamphlet K61.1 published by the American National Standards Institute, Inc. Supplemental information pertinent to ammonia storage tank installation and maintenance has been added.

We believe the information contained in this manual to be accurate and reliable. However, Tanner Industries, Inc. assumes no liability or responsibility in connection with the information or suggestions herein contained. Moreover, it should not be assumed that every acceptable test or safety procedure or method, precaution, equipment or device is contained within, or that abnormal or unusual circumstances may not warrant or suggest further requirements or additional procedures. The Company neither represents nor warrants the excerpted material from said pamphlets, and the pamphlets themselves should be read for a complete statement of their contents.

The information contained in this manual should not be confused with federal, state, municipal or insurance requirements, or with national safety or building codes, and no representations nor warranties are made with respect thereto.

Addendum: DWGS. 8010, 8011, 8014 & 8019.

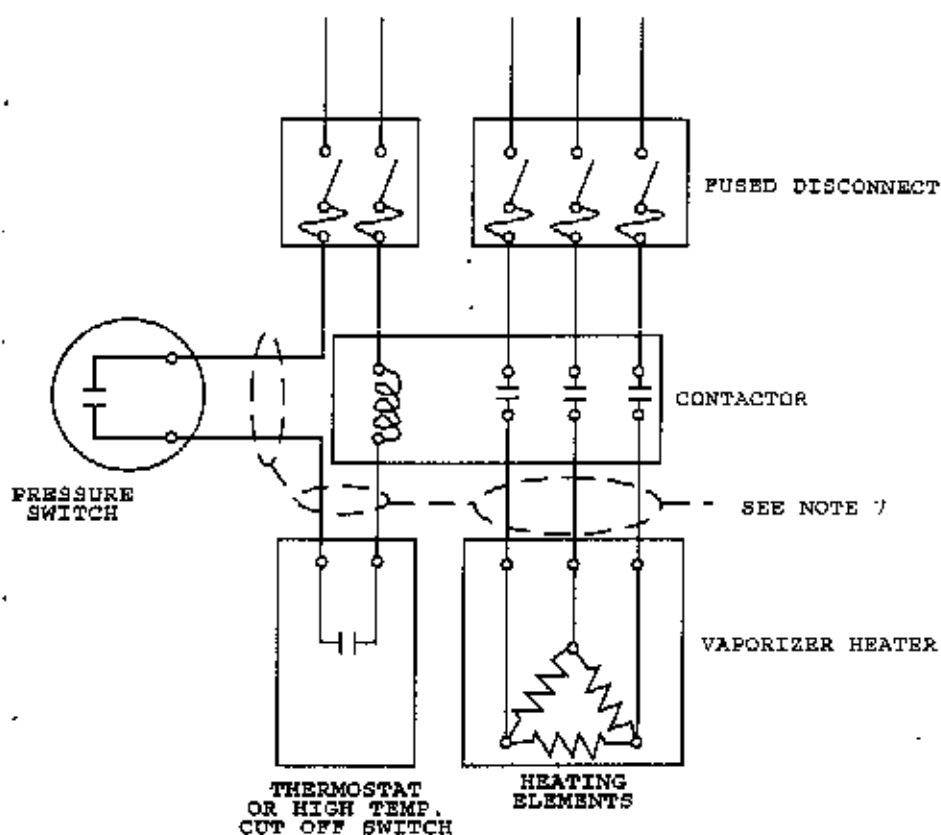

NOTES:

1. 115 VOLTS, 60 CYCLES IS REQUIRED FOR THE CONTROL CIRCUIT. THE VAPORIZER HEATING ELEMENTS ARE DESIGNED FOR 240 VOLT OR 480 VOLT, SINGLE OR THREE PHASE OPERATION AND ARE USUALLY RATED FOR 7.5 KW. THE FUSE REQUIREMENTS UNDER THESE CONDITIONS ARE 20 AMPS FOR 240 VOLT OPERATION AND 10 AMPS FOR 480 VOLT OPERATION.
2. THE FUSED DISCONNECT AND CONTACTOR ARE TO BE SUPPLIED BY THE CUSTOMER.
3. THE PRESSURE SWITCH CLOSES ON LOW PRESSURE. SET THE LOWER SET POINT ABOUT 10 PSI HIGHER THAN THE LOWEST PRESSURE REQUIRED. SET THE UPPER POINT ABOUT 10 PSI ABOVE THE LOWER SET POINT.
4. **IMPORTANT** - POWER MUST NOT BE APPLIED TO THE VAPORIZER HEATER UNLESS THE VAPORIZER CONTAINS LIQUID AMMONIA. OTHERWISE, HEATER BURNOUT WILL OCCUR.
5. THE THERMOSTAT SHOULD BE SET TO ITS HIGHEST TEMPERATURE SETTING.
6. VAPORIZER EQUIPPED STORAGE TANKS SHOULD BE ELECTRICALLY GROUNDED.
7. CONDUIT SEAL FITTINGS AND BARRIER SEAL COMPOUND IS RECOMMENDED.

TANNER IND., INC.
<u>VAPORIZER WIRING DIAGRAM</u>
DATE: MAY 1995 DWG.NO. 8010

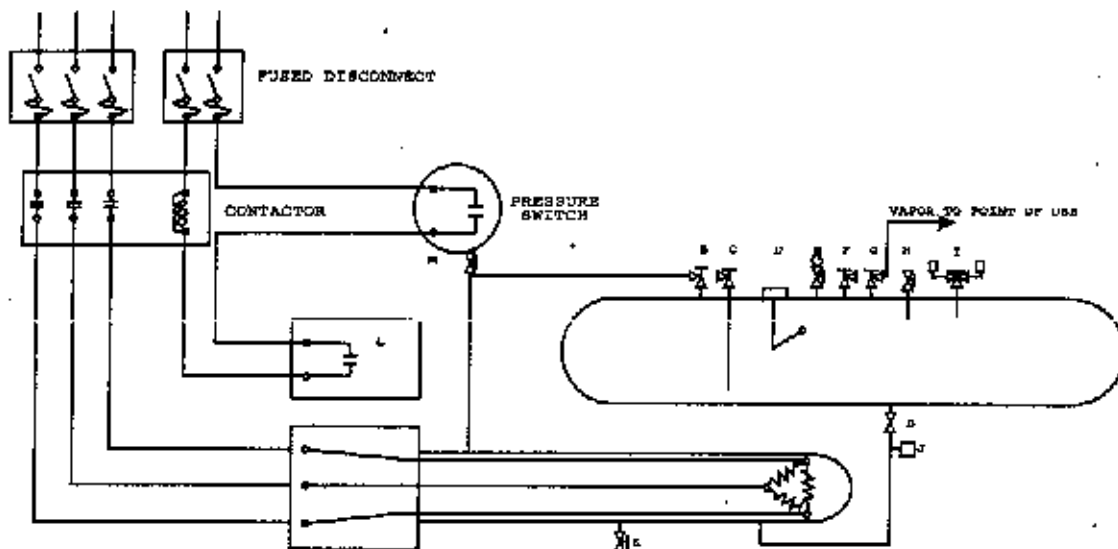

- A: PRESSURE SWITCH ISOLATING VALVE
- B: VAPORIZER ISOLATING VALVE
- C: LIQUID FILL CONNECTION
- D: FLOAT GAUGE
- E: PRESSURE GAUGE WITH ISOLATING VALVE
- F: FILL CONNECTION, VAPOR RETURN
- G: CUSTOMER SERVICE CONNECTION
- H: 85% OUTAGE GAUGE
- I: SAFETY RELIEF VALVES & 3-WAY VALVE
- J: HYDROSTATIC RELIEF VALVE
- K: VAPORIZER DRAIN VALVE
- L: THERMOSTAT OR HIGH TEMP. CUT-OFF SWITCH

NOTES ON OPERATION

1. VAPORIZER ISOLATING VALVES MUST BE OPEN AND LIQUID AMMONIA IN THE TANK BEFORE POWER IS APPLIED TO THE HEATERS.
2. THE PRESSURE SWITCH LOWER SET POINT SHOULD BE SET SLIGHTLY ABOVE THE MINIMUM OPERATING PRESSURE REQUIRED. THE UPPER SET POINT SHOULD BE SET ABOUT 10 PSI ABOVE THE LOWER SET POINT. THE PRESSURE SWITCH ISOLATING VALVE MUST BE OPEN.
3. THE THERMOSTAT SHOULD BE SET TO ITS MAXIMUM TEMPERATURE SETTING.
4. SHOULD ONE OF THE SAFETY RELIEF VALVES START TO LEAK, IT MAY BE ISOLATED USING THE 3-WAY VALVE. THE OTHER SAFETY RELIEF VALVE IS ADEQUATE, BY ITSELF, TO PROTECT THE TANK.
5. TANKS THAT ARE EQUIPPED WITH VAPORIZERS SHOULD BE ELECTRICALLY GROUNDING.

TANNER IND., INC.

TYPICAL STORAGE TANK W/VAPORIZER

DATE: MAY 1995 DWG.NO. 8011

PROVIDE A 2 FT. MINIMUM CLEARANCE ON ALL SIDES FOR INSPECTION AND MAINTENANCE PURPOSES.

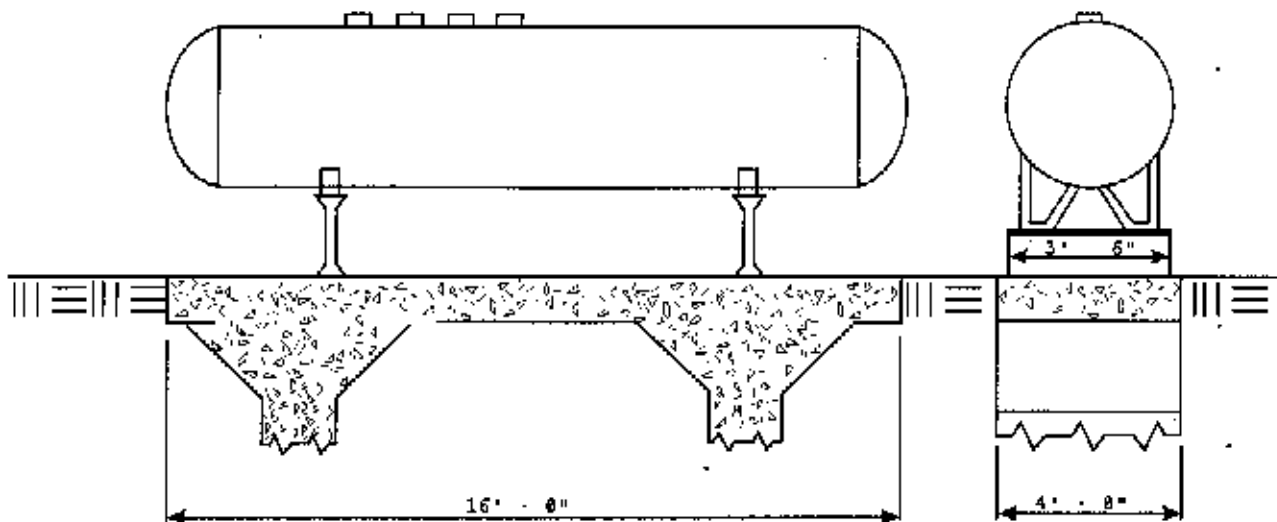

THE DISTANCE BETWEEN THE TANK LEGS (APPROXIMATELY 9 FT.) WILL VARY WITH TANK MANUFACTURER.

APPROX. OVERALL DIMENSIONS: 3'-6" DIA. X 16'-1" LONG

APPROX. WEIGHT EMPTY: 2750 LBS.

APPROX. WEIGHT AT 85%: 7000LBS.

TYPICAL 1000 GALLON ANHYDROUS AMMONIA TANK

INSTALLATION NOTES:

1. INSTALL THE TANK IN A LOCATION WHERE IT WILL NOT BE SUBJECTED TO DAMAGE BY VEHICLES, CORROSIVE MATERIALS OR FALLING OBJECTS.
2. A PROTECTIVE ENCLOSURE (CHAIN LINK FENCE) SHOULD BE PROVIDED IF THE TANK COULD BE SUBJECTED TO VANDALISM.
3. THE TANK SHOULD BE LOCATED AWAY FROM BUILDING AIR INTAKES, OPEN WINDOWS OR ANYWHERE THAT THE ODOR OF AMMONIA COULD CAUSE PROBLEMS.
4. PIPING CONNECTIONS TO THE TANK SHOULD ALLOW FOR TANK MOVEMENT DUE TO SETTLING, EXPANSION OR CONTRACTION
5. TANKS EQUIPPED WITH VAPORIZERS SHOULD BE ELECTRICALLY GROUNDED.

TANNER IND., INC.

TANK INSTALLATION DRAWING

DATE: MAY 1995 DWG.NO. 8014

VAPOR PRESSURE - TEMPERATURE RELATIONSHIP LIQUID ANHYDROUS AMMONIA

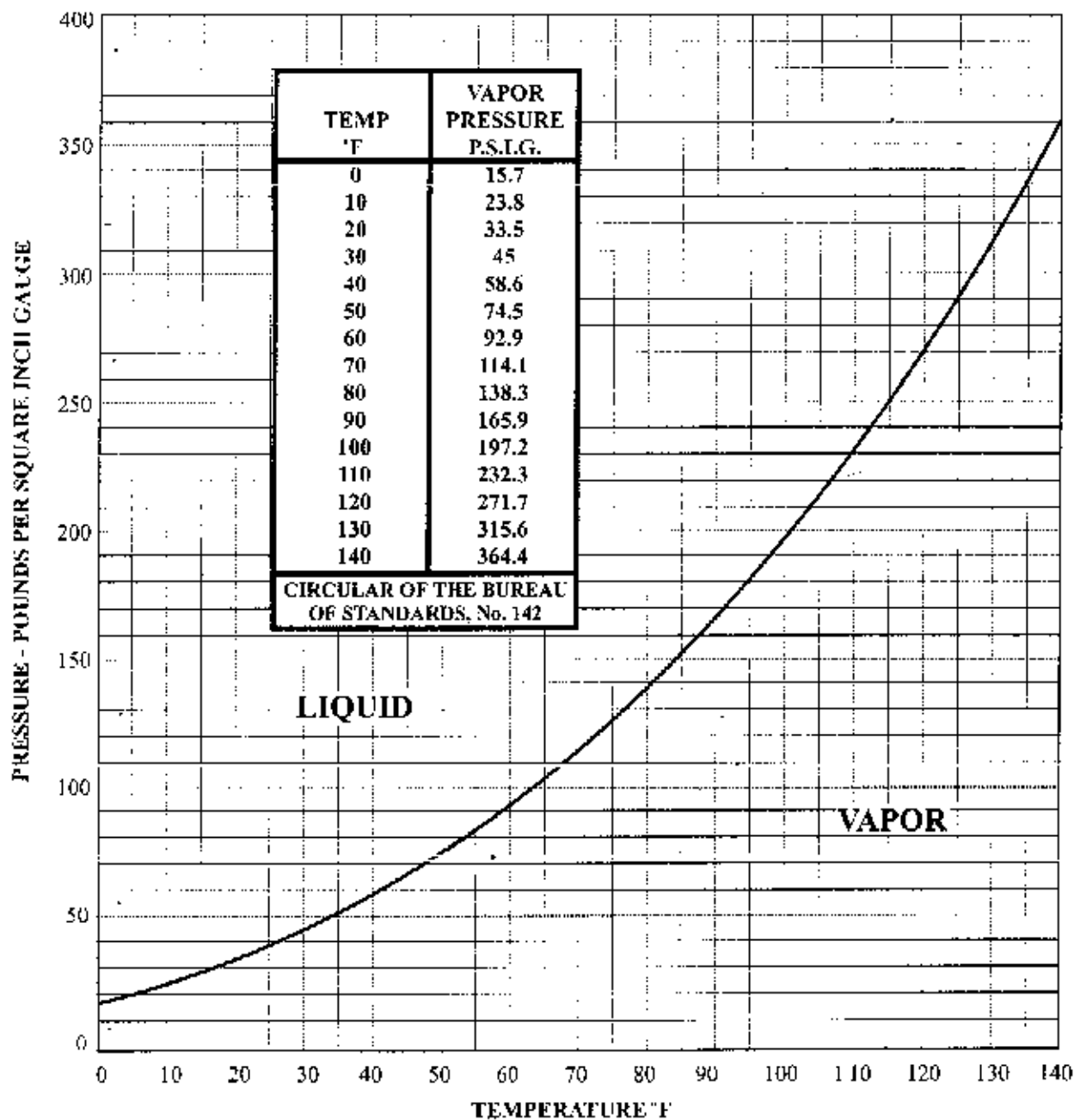

<i>TANNER IND., INC.</i>	
<u>VAPOR PRESSURE-TEMPERATURE CURVE</u>	
<i>DATE: MAY 1995</i>	<i>DWG.NO. 8019</i>